

3.2 Hängebrücke mit 2 Pylonen

Mainsteg Margetshöchheim-Veitshöchheim

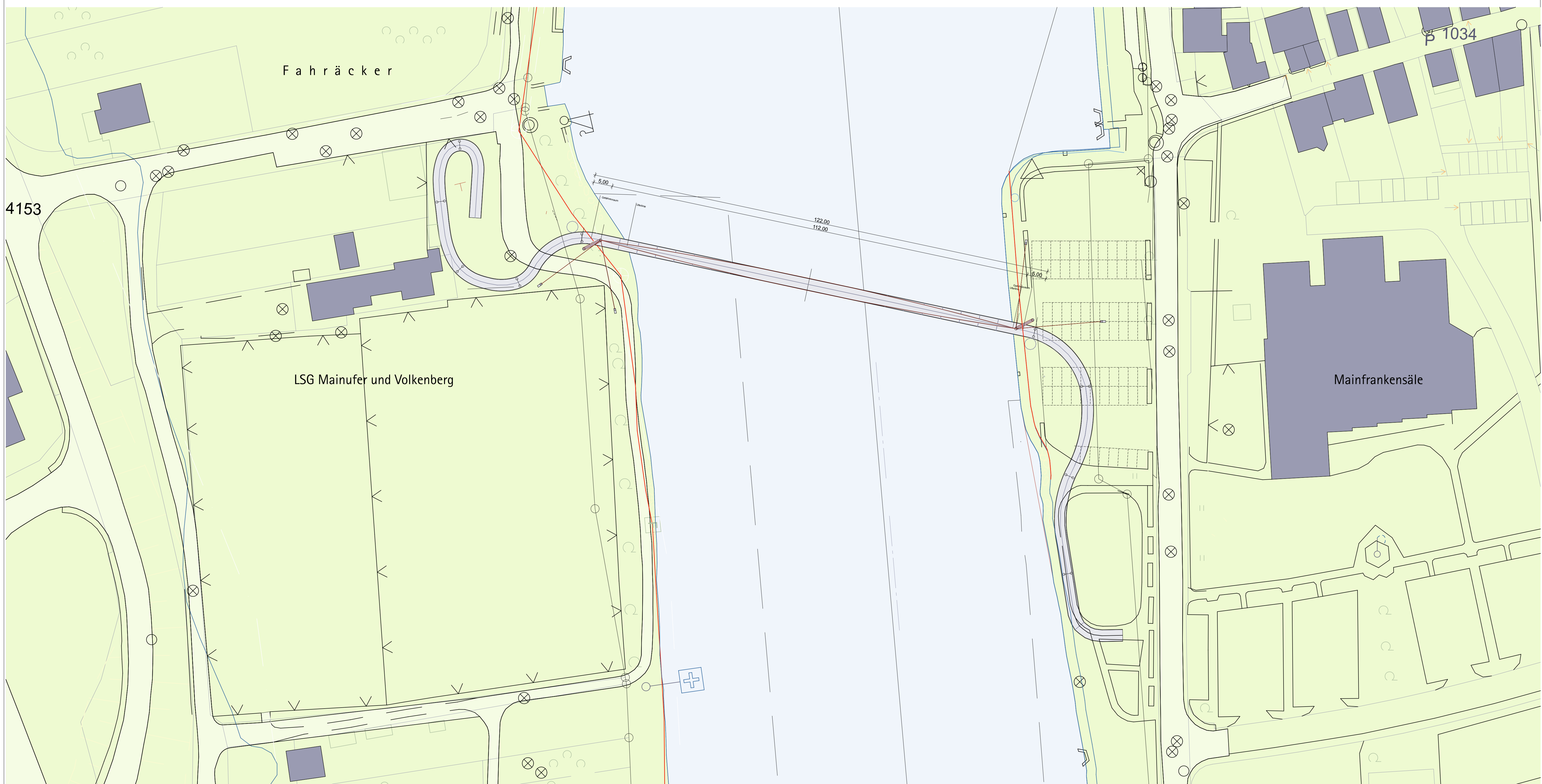

Grundriss M 1:500

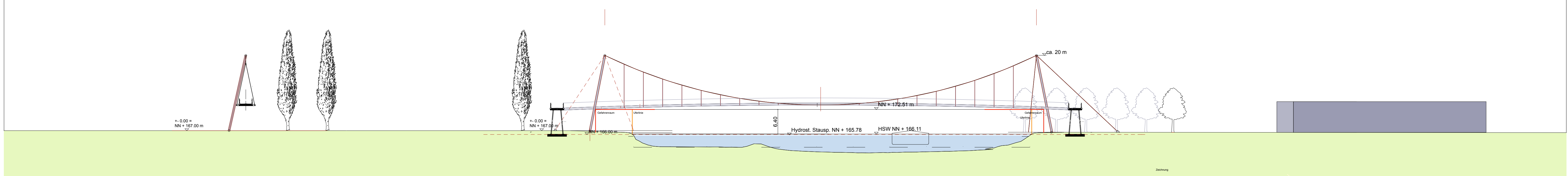

Querschnitt M 1:500

Ansicht M 1:500

Rampenquerschnitt M 1:50

Rampenlängsschnitt M 1:50

Regelquerschnitt M 1:50

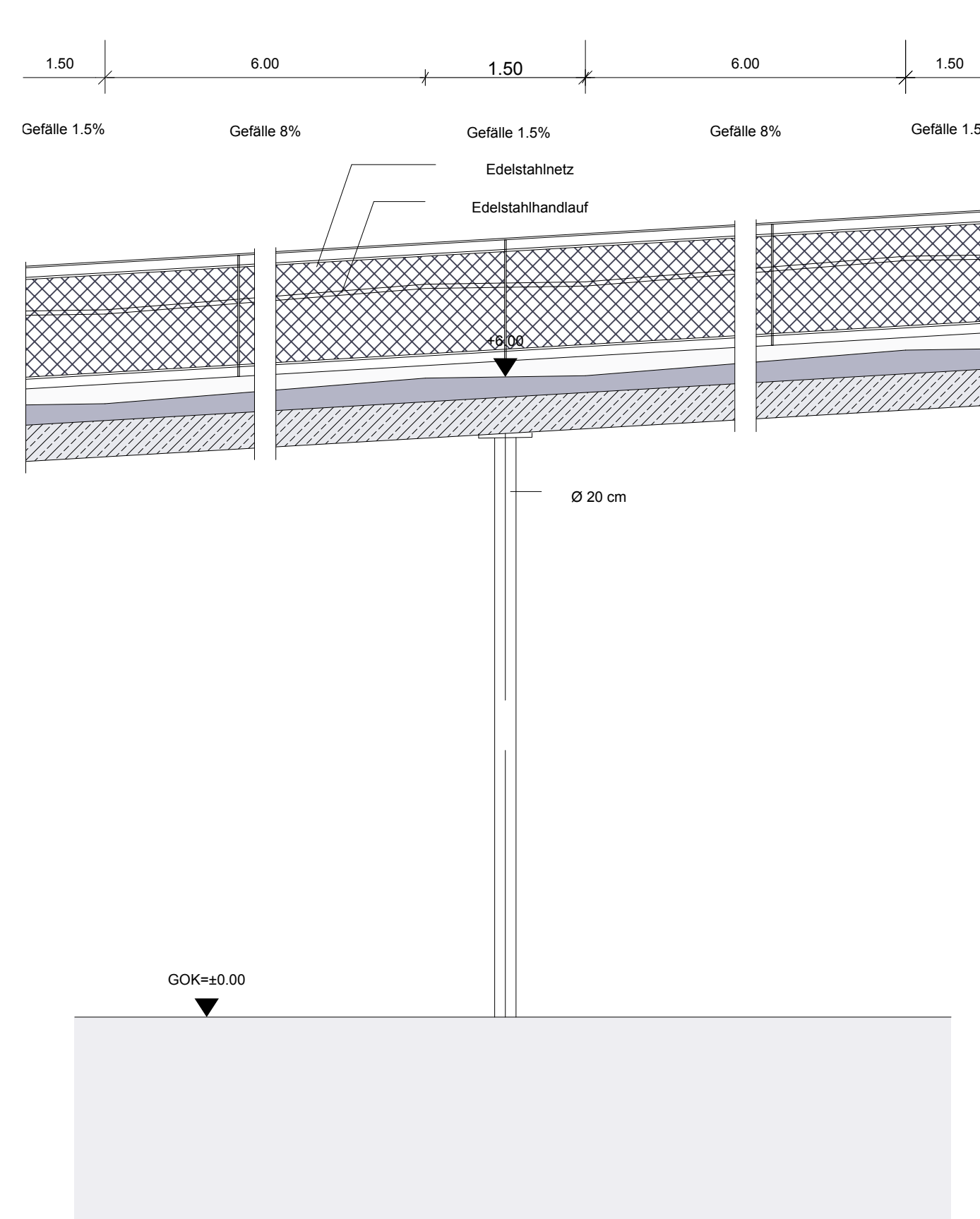
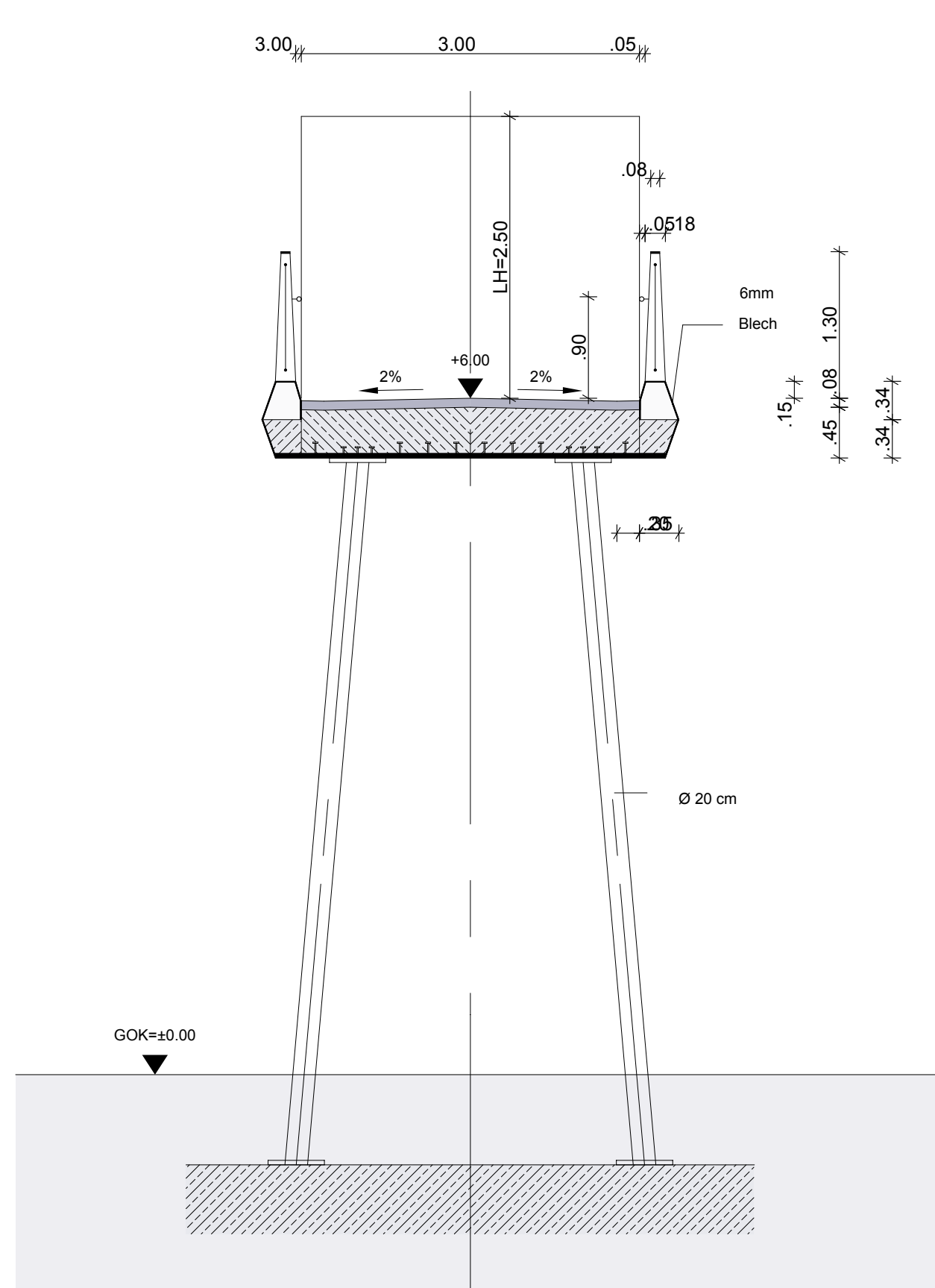

Mitte -> Viertelpunkt

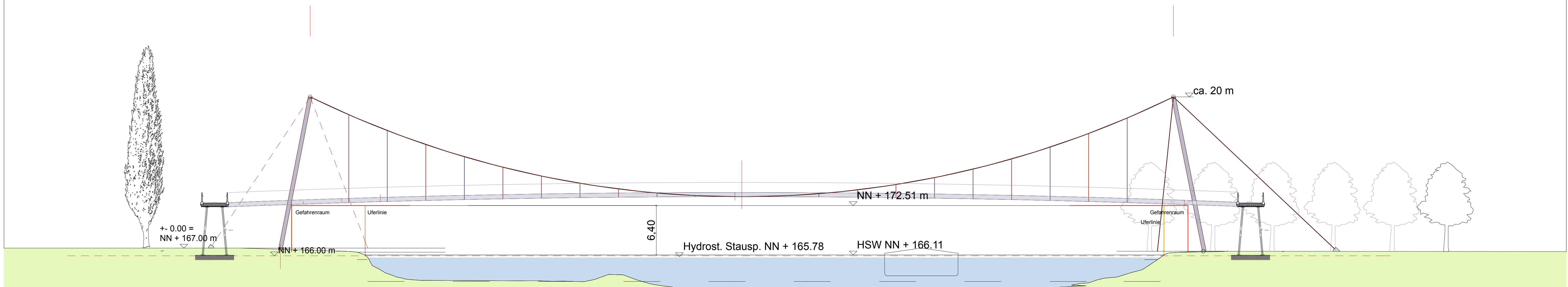
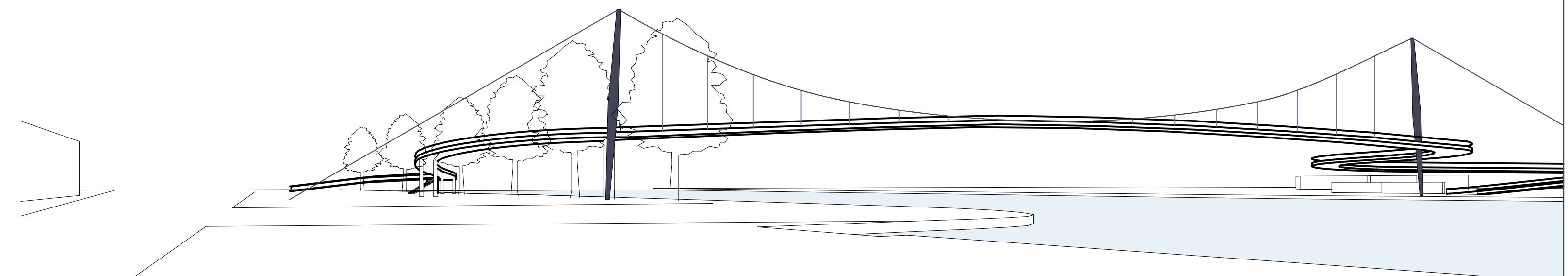
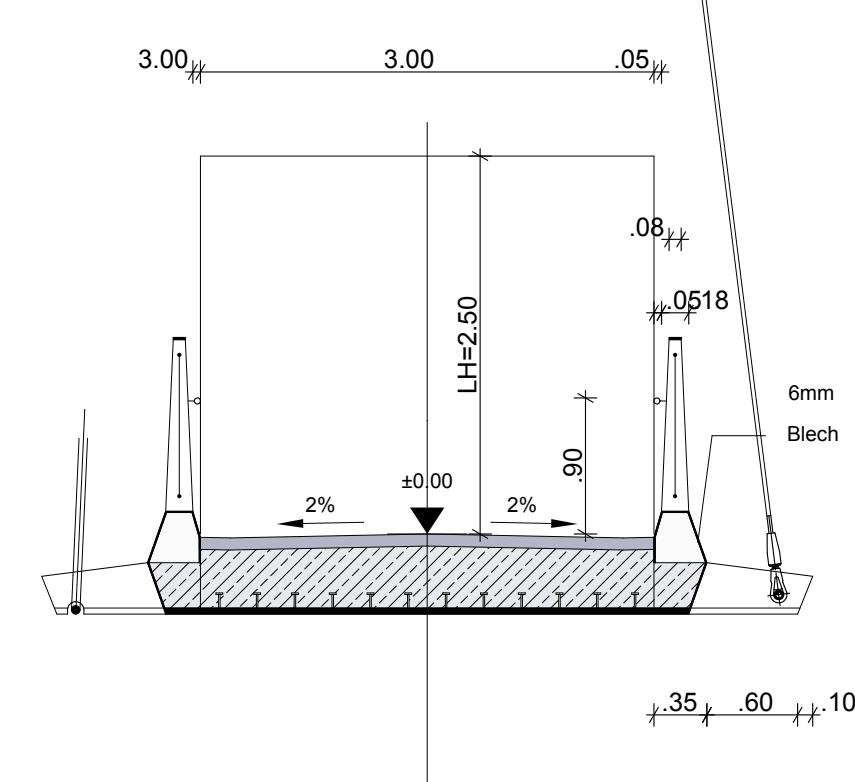

Ansicht M 1:250